

# FILTERS

# CCFG Legacy™ Fiberglass Sand Filters

## Face Piping Configurations

Filter Model Number	Tank Conn	Filter Area (SF)	Max Flow (GPM)	All dimensions are in inches						Tank Shipping Weight (LBS)	Operating Weight (LBS)
				A	B	C	D	E	F		
36CCFG-3	3	6.5	98	58	37	43 1/4	37 1/4	11 7/8	11 7/8	88	1380
42CCFG-3	3	9.0	135	64	43	44	38	13 3/4	13 3/4	111	2170
48CCFG-3	3	11.8	177	70	49	57 3/4	47 1/4	14 1/8	21 5/8	189	3410

Face Piping Dimensions		Face Piping Size (inches) Dual Tank		
Dimensions				
	3x3	4x3	6x3	
G	7	8	13	
H	7	8	13	

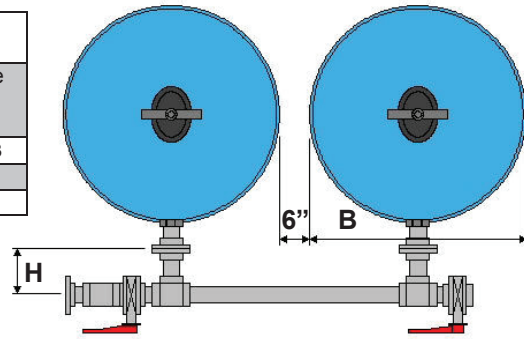

Models 36 & 42CCFG include 6"x9" access port.

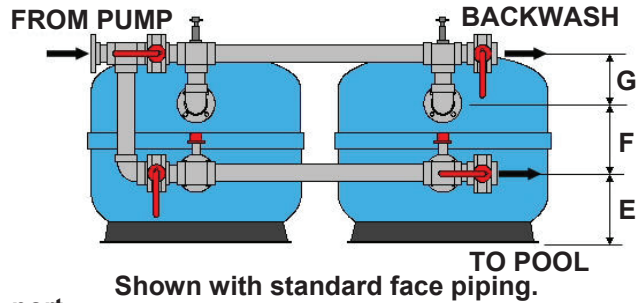

Shown with standard face piping.

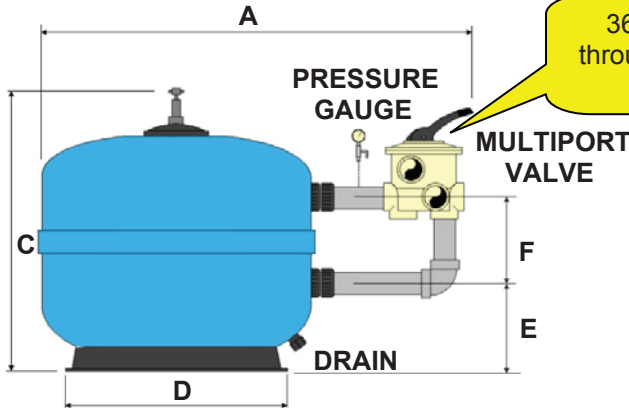

36" Filters fit through standard doors!

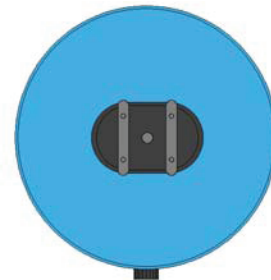

Model 48CCFG includes a 14"x18" access manway.

All dimensions are in inches			
STANDARD MEDIA CHART			
Filter Model Number	Gravel (CF)	Filter Sand (CF)	Sand Depth
36CCFG-3	2	6	11
42CCFG-3	3	9	11
48CCFG-3	3	16	17

## MEDIA REQUIREMENTS

Depth and Media Quantities

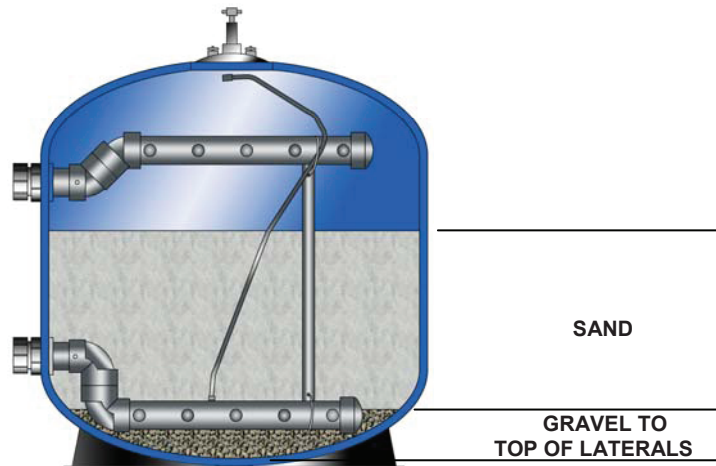

## **SECTION 13150 SWIMMING POOL FILTRATION, RECIRCULATION, CONTROL AND CHEMICAL EQUIPMENT**

### **INTENT**

- A. Purpose of the bid is to purchase and have installed a complete filtration and recirculation system for the swimming pool. It is intended to limit the bidding to a style of product and company that has a proven history and record of performance.
- B. Due to the specialized nature of certain components required for this project, these specifications, in some instances, refer to various components by trade or manufacturers name.
- C. Whenever a proprietary (trade) name is used within this Specification Section, it is used for informational purposes to describe a standard of required function, dimension, appearance and quality. References to materials by trade name, make or model number shall not be construed as limiting competition. All bidders are required to bid on the named manufacturer in the BASE BID. The Contractor may at his option, elect to bid using the products and/or services of alternate manufacturers listed as **ALTERNATES ON THE BID FORM**.

### **ALTERNATES**

- A. Other treatment systems will be considered only if a complete set of drawings and specifications detailing such equipment as it pertains to this project are submitted for evaluation ten (10) days prior to the bid date. The submission should include a list of five (5) operating installations within a reasonable distance of the jobsite. List should include the names and telephone numbers of the operating personnel. The technical contents of the submittal shall include hydraulic calculations, equipment fabrication details, filter room layout in plan and elevation views, warranties, installation and operating instructions.

**NOTE: This information must be submitted by a bidding contractor. Submittals will not be considered if provided directly by the alternate equipment manufacturer.**

- B. Alternates meeting the terms and conditions of the bidding documents will be acknowledged prior to bidding by addendum. No alternates will be considered after the bid.
- C. For any and all alternates approved in accordance with the above conditions, state the amount to be DEDUCTED from the BASE BID if an alternate filtration system is being offered. No provision has been or will be made for ADDITIVE bids.

### **SUBSTITUTIONS**

- A. No substitutions will be considered unless the specified product becomes unavailable due to no fault of the Contractor.

## **QUALITY ASSURANCE**

- A. Due to the specialized nature of the specified work and products, all bidders shall be required to have a minimum of five (5) years of operating history. The equipment described herein shall be products of a manufacturer regularly engaged in the fabrication of filtration and recirculating systems for at least fifteen (15) years and shall be a professional engineering corporation.
- B. The owner requires that filters bear the National Sanitation Foundation (NSF) seal for Standard #50. This NSF listing is required by the owner regardless of local health department regulations.
- C. The specified filter system shall have had an NSF listing for at least two (2) years prior to the project bid date.
- D. As assurance that each item of apparatus is properly sized to perform in conjunction with each other, the owner requires bidders to use the filter manufacturer as a single source of supply for the items of equipment as listed and described herewith.
- E. For projects that incorporate stainless steel gutter systems, the filter system and stainless steel gutter system shall be manufactured and supplied by the same company.
- F. The "EQUIPMENT SUPPLIER" shall be:

NEPTUNE-BENSON, INC.  
COVENTRY, RHODE ISLAND  
1-800-832-8002

## **GUARANTEE**

- A. The "EQUIPMENT SUPPLIER" shall guarantee that the equipment to be furnished is of the correct capacity, that the various parts are designed to operate correctly and in conjunction with each other, that if the installation is made in accordance with the project drawings and operated in accordance with the suppliers instructions, the system will perform the prescribed functions correctly, the water entering the pool will be clear, bright, free from suspended matter visible to the unaided eye, and will be sanitary to the satisfaction of all authorities having jurisdiction.

## **SUBMITTALS**

- A. Provide detailed shop drawings of the items of equipment being provided, indicating the dimensions, material of the filter tanks, exterior face piping, internal manifolds and laterals and filter media.
- B. Provide a complete set of operating instructions, embracing the operational functions and recurring maintenance processes involved in connection with the complete filtration system.

## **PART 2 - FILTER SYSTEM**

### **FILTER SYSTEM REQUIREMENTS**

1. The system shall be supplied complete by the manufacturer and shall include: internals, face piping and valves, gauge panel with tubing and petcocks, sight glass, air relief connection, bottom drain connection with internal strainer.
2. System shall be fabricated and fully assembled at the manufacturer's plant for pressure testing and dimensional verification. System shall be knocked down for shipping purposes in subassemblies for minimum field assembly. Internal manifold and lateral piping shall be factory installed and shipped in place.

### **FILTER SYSTEM CAPACITY**

- A. The system capacity, size, performance and model number shall be as shown on the drawings.

### **LEGACY FILTER TANK**

- A. The equipment described herein shall be products of a manufacturer regularly engaged in the fabrication of fiberglass pressure vessels for at least 10 years.
- B. The filter tank(s) shall be no less than " diameter suitable for 50 psi working pressure and designed with a 4:1 safety factor. In connection with Section X of the ASME Code, the vessel test pressure should not exceed the design pressure by more than 10%.
- C. The filter shall be an upright cylinder with semi-hemispherical ends and mounted onto a pedestal style base for support. 36" and 42" access shall be through a 9" x 11" nominal hand hole (8" x 10" opening) with o-ring seal and secured with a yoke. Hand hole shall be positioned so that internal pressure from the filter will augment the seal. 36" diameter shall have a loose base to allow passage through a STD 36" door opening.

**OR –**

- D. The filter shall be an upright cylinder with semi-hemispherical ends and mounted onto a pedestal style base for support. 48" diameter tank access shall be through a 14" x 18" nominal manway (13" x 17" opening) with o-ring seal and secured with two (2) composite yokes. Manway shall be positioned so that internal pressure from the filter will augment the seal.
- E. 36", 42" and 48" diameter tanks shall include a combination drain/media dump port. All models shall be provided with a 1/4" petcock for air relief and a 2" diameter 0-60 psi pressure gauge. Each filter tank shall be equipped with the necessary inlet/outlet bulkhead connections for the internal and external piping.

- F. The resin shall be a commercial grade 1 premium corrosion resistant polyester that has been evaluated in a laminate test in accordance with ASTM C-581 in service comparable to the intended application. No thixotropic agent shall be added. Resin pastes used to fill crevices may contain thixotropic agents provided that all such areas are subsequently covered with a full corrosion resistant barrier laminate. Exterior surface shall be an ultraviolet inhibiting premium grade gel-coat. The laminate for the entire tank shall be corrosion resistant with multiple structural reinforcing layers built up to the required design thickness.
- G. Filter shall carry a five (5) year limited warranty.
- H. Filter shall carry NSF Standard 50 listing.

TABLE 1  
LAMINATE MINIMUM PHYSICAL PROPERTIES

Tensile Strength	26,500 psi ASTM D638
Flexural Strength	39,400 psi ASTM D790
Izod Impact Strength	29.0 ft-lbs/in ASTM D256
Barcol Hardness	50 ASTM D2583
Water Absorption	0.09% ASTM D570

**LEGACY INTERNAL PIPING**

- A. The internal distribution system shall be a horizontal header/lateral arrangement. The headers shall be 3" Schedule 80 PVC construction. Lateral connections shall be spaced no more than 6" on the centers and shall be 1½" FPT connections.
- B. Underdrain laterals shall consist of 1½" Schedule 80 PVC pipe with .012" wide machined double slotted openings on 1/8" centers. Machined openings shall be designed to retain all media particles as small as .30 mm particle size. Each lateral shall be fabricated with a socket cap on one end and male adapter on the other. Both fittings to be solvent welded to the slotted pipe. Laterals shall be fitted with a rubber o-ring to allow for proper positioning of the machined openings.
- C. Overdrain laterals shall consist of 1½" Schedule 80 PVC pipe with 1/4" wide machine slotted openings on 1¼" centers. Overdrain laterals shall be designed to provide uniform distribution and unrestricted flow during filter and backwash cycles. Fabrication shall be as specified for underdrain laterals.
- D. All internal components of the filter shall be factory installed.
- A. Internal piping shall carry a three (3) year warranty.

## **LEGACY FACE PIPING**

- A. External face piping shall be Schedule 80 PVC pipe and fittings with solvent cemented joints.
- B. A six position lever operated multiport valve shall be provided for filter control. The valve shall provide for:
  - Filtering to pool
  - Backwash to waste
  - Media rinse to waste
  - Recirculation bypass to pool
  - Filter bypass to waste
  - Winterization (closed)
- C. The valve body shall be constructed of ABS with EPDM o-ring seal and Kynar spider gasket. 2" valves shall have threaded ports for piping connections. 3" valves shall have socket connections.
- D. 2" valves shall include integral mounted sight glass with o-ring. 3" valves shall include 1½" diameter polycarbonate glass with 3" saddle for field mounting. Sight glasses shall be rated for 50 psi minimum.
- E. Valves shall carry a one (1) year warranty.

## **LEGACY AUTOMATIC BACKWASH**

- A. An electrically operated programmable system shall be furnished to provide automatic activation of the backwash and filter cycles on a present time basis and/or pressure variations.
- B. Electrical power source shall be 24 volt, 50/60 hertz. External step down transformer required from 120 volt power source.
- C. The valve mounted programmer shall include the following devices:
  - 10-100 psi adjustable pressure switch for pressure activated backwash.
  - A 7 day, 12 position clock for time activated backwash. Clock shall allow settings for up to two (2) backwash cycles per day.
  - Recirculation pump relay contacts to start/stop pump between valve position changes. (External contractor and motor starter is required).
  - Touch pad activation to allow manual operation of backwash and rinse cycle.
  - Two (2) adjustable potentiometers (POTI2, POTI1) to allow backwash duration setting between 1 – 11 minutes and rinse cycle duration setting between twenty (20) seconds – 4 minutes & 20 seconds.
- D. Enclosure shall be NEMA IV rated.
- E. Automatic controls shall carry a one (1) year warranty.

## **FACE PIPING – FOR USE WITH BUTTERFLY VALVES**

- A. External face piping shall be Schedule 80 PVC pipe and fittings. Flanges shall be located so as to allow for easy dismantling of face piping. All fittings shall be solvent cemented.
- B. Piping shall be drilled and tapped where necessary to accommodate gauge tubing connectors.
- C. All valves 3” – 12” shall be constructed with cast aluminum ASTM S12A housing and fully coated with Rilsan on all interior and exterior surfaces. Internal components include EPDM resilient lining, Rilsan coated ductile iron disc and T304 stainless steel shaft. Valves 14” and larger shall be constructed with cast iron housing epoxy coated and with nylon coated ductile iron disc.
- D. Standard accessory items shall include sight glass rated for 50 psi with polycarbonate glass, remote mounted gauge panel with two 4½" diameter pressure gauges, ¼" petcocks, ¼" poly vent tubing with PVC compression adapters.
- E. Face piping shall be fully factory assembled, knocked down and crated for shipment. The warranty of the face piping shall be provided by the filter manufacturer. Field gluing or assembly of the face piping by anyone other than the filter manufacturer will not be accepted.
- F. Face piping arrangement shall be as indicated on the drawings.

## **AUTOMATIC AIR RELIEF VALVE**

- A. 1" valve shall be provided to automatically and continuously release air in the filter. The valve shall be fabricated of plastic with Buna-N seals. A plumbing kit shall be provided with two (2) PVC ball valves to allow manual air relief and isolation of the automatic valve. Valves fabricated of cast iron, bronze or stainless steel shall not be acceptable

## **SINGLE LEVER LINKAGE**

- A. A clevis and rod linkage shall connect the four butterfly valves provided with the face piping. Assembly shall be designed so that filter and backwash cycles can be accomplished by simply raising or lowering the operating handle.
- B. Connecting pieces shall vary with size of face piping in order to operate with suitable mechanical advantage.
- C. All linkage parts shall be T304 stainless steel.
- D. Linkage shall be designed so that all valves operate simultaneously eliminating the possibility of water hammer action. Each valve shall be adjustable to provide for accurate positioning and tight shut off.

- E. All linkage components shall be grit blasted to a 1.2 mil profile. Blast media shall be completely non-ferric.
- F. All linkage components shall be finish coated with 3-4 mils DFT of Type 316 pigmented stainless steel paint.

### **SLM ACTUATOR**

- A. An electromechanical actuator shall activate the single lever linkage. Actuator shall consist of 115 volt AC totally enclosed motor attached to a worm drive and 1½" diameter telescoping tube with 12" stroke length. Cycle time shall be fifteen (15) seconds with a load capacity of five hundred (500) pounds. Unit shall be complete with built-in, adjustable limit switches and clevis end fittings.
- B. Actuator shall be factory wired with a 10' cable with molded connector. Cable shall be type STD #16 AWF 6 conductor rated for 600 v/8 amps.
- C. Cable shall be moisture, oil and dirt resistant with threaded male connector providing strain relief low risk for wire breakage and connection integrity.

### **THREE (3)-WAY VALVE CONTROL ASSEMBLY**

- A. A mechanical linkage shall connect two (2) valves in order to create simultaneous movement.
- B. Connecting pieces shall vary with the size of face piping in order to operate with suitable mechanical advantage.
- C. All linkage parts shall be T304 stainless steel.
- D. Linkage shall be designed so that filter and backwash cycles can be accomplished by repositioning a pair of valves.
- E. Each pair of valves shall be operated as specified with lever, gear or electric actuation.
- F. All linkage components shall be grit blasted to a 1-2 mil profile. Blast media shall be completely non-ferric.
- G. All linkage components shall be finish coated with 3-4 mils DFT of Type 316 pigmented stainless steel paint.

### **VALVE OPERATORS**

#### **LEVER OPERATORS DOMINION™**

- A. Valves shall be provided with 6 position latch lock handles.

- B. Latch lock handles shall be constructed of epoxy coated cast aluminum and shall include a spring loader lever for position lock.
- C. Lever shall be capable of holding the disc in any of the locking positions with no movement up to the full pressure rating of the valve.

## **GEAR OPERATORS**

- A. Valves shall be provided with infinite position gear operators.
- B. Gear case (body) shall be constructed of cast iron painted internally and externally for maximum protection.
- C. Enclosure shall be sealed to IP65 and maintenance free.
- D. Self locking gearing shall be capable of holding the disc in any position with no movement up the full pressure rating of the valve.
- E. Gear operator shall provide 90° of travel with  $\pm 5^\circ$  adjustment in closed position.
- F. Gear operator shall include a non-corrosive sealed indicator for remote visibility.
- G. Gear operator shall include manual adjustment capabilities.

## **MODEL MFP 2 AUTOMATIC CONTROLLER**

- A. The controller shall govern the operation of the filter system by means of a programmable logic controller. All power to the controller and valves shall be 120 VAC or 230 VAC – single phase.
- B. The controller shall be housed in a Nema 4X fiberglass polyester enclosure with padlockable stainless steel snap latch hinges.
- C. The controller shall include a 4-row x 24 character LCD display with a 16 button numeric tactile feedback keypad and programmable function keys with LED's. The unit shall display system operation and status functions.
- D. The controller shall include (5) miniature plug-in double pole/double throw (DPDT) relays and (4) quick disconnect fuse holders fully integrated to manage the system functions.
- E. A pressure switch shall be installed to sense and signal for backwash actuation based on a preset pressure drop.
- F. ½" strain relief connections shall be provided in the bottom of the enclosure for all of the necessary input connections.

G. The Model MFP 2 Controller shall provide the following operational features:

1. Manual backwash initiation
2. Automatic backwash initiation (pressure and/or time options)
3. Timer for time clock backwashing
4. Fixed backwash duration and delay features
5. Real time clock with battery backup of data entry to maintain time during power failure.
6. Capable of controlling up to (4) filters and (1) one priority valve

H. All controller programming shall be accomplished using on-screen instructions.

### **ELECTRIC OPERATORS**

- A. Electric service shall be 110 VAC.
- B. Operator housing shall be corrosion resistant NEMA 4X (IP65).
- C. Electrical connectors shall be four-pole industrial style and meet DIN 43650 standards. Plug connection shall be gasketed and mechanically secured with a stainless steel screw. Harness assemblies from operator to control panel shall be factory fabricated. No field wiring shall be required.
- D. Drive assembly shall include hardened steel and polyamide reduction gears with permanent lubrication.
- E. Operator shall be equipped with a manual override.
- F. Operator shall have a visual position indicator.
- G. Electric drive motor minimum duty cycle rating to be 35%. Overloading protection shall be self-resetting.
- H. Limit switches shall be provided to allow adjustment of cycle.
- I. Two additional limit switch contacts shall be provided for indication or auxiliary.

### **PNEUMATIC OPERATORS**

- A. The actuators shall be double acting with valve mounted drilling to ISO 5211.

B. The actuators shall include (2) 1/4" FPT ports for open / close connections. Flow control valves with quick connect fittings shall be provided at each port to allow speed control adjustment for the open / close function of the actuators.

C. Materials of Construction

1. Body: aluminum alloy, extruded acc. to ASTM 6063, anodized acc. To UNI 4522
2. Ends: Die-cast in aluminum alloy acc. To ASTM B179, epoxy-polyester coated
3. Pistons: Die-cast in aluminum alloy acc. To ASTM B179
  
4. Pinion: Nickel-plated steel
5. Slideways: Acetal resin (LAT LUB 731320T)
6. Fasteners: AISI 304 Stainless steel
7. Springs: Epoxy coated steel, pre-compressed
8. Seals: NBR Nitrile rubber
9. Lubricant: MoS2

D. The actuators shall be factory lubricated to allow for 1,000,000 maneuvers.

E. The actuators shall have adjustable travel stops for both directions.

F. Working temperature limits: 4°F to 186°F.

H. A tool kit for adjustment of pneumatic actuators shall be provided by the filter manufacturer.

**FILTER / REGULATOR**

A. Each filter shall include a combination filter / regulator. The regulator shall be adjustable from 0 – 120 p.s.i. 1/2" F.P.T. connections shall be provided for field installation of air lines.

**WATER SEPARATOR**

A. One water separator with automatic drain shall be included for each air compressor supplied. 1/2" F.P.T. connections shall be provided for field installation of air lines.

**AIR COMPRESSOR**

A. The system will require (1) air compressor per mechanical room. The following is the minimum requirement: 30 gallon tank, 2 HP 120v, 1 phase, 15 amp, 5.5 CFM @ 90 psi, air pressure gauge, pressure relief valve, belt guard, pressure switch, air filter

## **SOLENOID VALVES**

- A. Each filter shall include the required number of single solenoid, 4-way valves mounted on a multi-station manifold for operation of the pneumatic actuators.
- B. The solenoids valves shall include lighted DIN connectors.
- C. The solenoid valves shall be factory lubricated and shall not require any field lubrication.
- D. The solenoid valves with multi-station manifold shall be located on the gauge panel, factory wired and include quick connect fittings for attachment to the pneumatic actuators.
- E. The solenoid valves shall be SMC Series SY 7000.

## **MEDIA**

- A. Gravel support media of a hard coarse aggregate with a subangular grain shape with a particle size of 1/8" x 1/4" shall be used on the inside of the bottom head to the elevation where the filter media commences. The specific gravity shall not be less than 2.5. Support media shall be placed by hand to avoid damage to the underdrain system and leveled before the addition of the upper layer of filter media. Concrete underfill is not recommended. Support gravel shall be delivered and stored in 100 pound bags (approximately one cubic foot) for ease of handling and elimination of possible contamination. Media shall be free from minerals which may precipitate onto pool surfaces.
- B. Sand shall be a carefully selected grade of hard, uniformly graded silica material. Media shall be naturally rounded particles of silica or milled angularly shaped particles of silica quartz. Sand shall have a particle size between .45mm and .55 mm.(#20). No more than 1.5% shall be allowed to pass through a #40 sieve (.0164"). Uniformity coefficient shall not exceed 1.53. Specific gravity to be not less than 2.5. Filter shall contain a minimum bed depth as shown on the drawings. Systems which do not provide a minimum bed depth as shown on the drawings will not be acceptable. Sand shall be delivered and stored in 100 pound bags (approximately one cubic foot) for ease of handling and elimination of possible contamination. Media shall be free from minerals which may precipitate onto pool surfaces.

Each filter tank shall be provided with media quantities as shown on the drawings

## **FILTER SYSTEM PACKAGING**

- A. All filter piping and valves shall be factory assembled and knocked down into sub-assemblies for shipment.
- B. The components shall be carefully packaged in a totally enclosed wooden crate to prevent damage during transport.

**PART 4 – WARRANTIES**

**NEPTUNE-BENSON, INC.** (Manufacturer) warrants for a period of five (5) years from the date of delivery to the original purchaser, that the fiberglass vessel shall be free from defects in workmanship or material when used in accordance with the Manufacturer’s installation, operating and maintenance instructions. Liability under the foregoing warranty is limited to either repair, or replacement, at the Manufacturer’s option, within a reasonable time after receipt of notice in writing of a defect, and is expressly conditioned upon the receipt of such notice within the period of the warranty indicated and shall in no event include any resulting or consequential damages. Field inspection of the reported defect shall be performed by an authorized factory representative.

Filter tank shall be warranted as follows:

Year 1	100% of purchase price
Year 2	50% of purchase price
Year 3	40% of purchase price
Year 4	30% of purchase price
Year 5	20% of purchase price

The cost of media and/or tank removal, reinstallation and transportation shall be borne by the user.

Multiport valves, manhole covers, gaskets, securing yokes and fasteners shall be warranted for a period of (1) year.

Plumbing apparatus which makes up the complete filter unit, such as valve linkage, internal and external piping shall be warranted for a period of three (3) years. Dominion or Viceroy butterfly valve bodies shall be warranted for a period of five (5) years. All operators shall be warranted for a period of (1) year. All components are subject to the conditions in the Manufacturer’s installation, operating and maintenance instructions.

The component parts that constitute the automatic backwash shall be warranted for a period of one (1) year and are subject to the conditions of the Manufacturer’s installation, operating and maintenance instructions.

Items of equipment by other manufacturers carry the standard warranties as provided by each manufacturer and are subject to the conditions of the original equipment manufacturer’s installation, operating and maintenance instructions.

Issuance of warranty is in consideration that all indebtedness to Neptune-Benson for contract work has been satisfied.